



ERK Series Enclosure

Middle Atlantic Products, Inc.**SEISMIC RATED**

The ERK Series 19" welded rack enclosures
Advanced manufacturing techniques provide highest quality and lowest price

Features

- Fully welded construction
- 1/8" thick structural steel internal braces
- UL listed
- Seismic rated (when used with ERK-Z4 option)
- 22" OD width, available 20" or 25" OD depth
- 1/2", 3/4", 1" & 1 1/2" electrical knockouts on removable rear plates
- Standard solid front, optional rear 11-gauge 10-32 threaded rackrail standard
- Keylocked solid rear door standard, optional vented rear doors available
- Optional front doors available
- Configurable top options on 44, 40, and 35 space sizes
- Durable black textured powder coat finish

**ERK-4425**

CABINET ACCESSORIES

ADDITIONAL RACKRAIL KIT
CASTER BASE
COPPER BUS BAR
CRATING SERVICE
DOCUMENT POCKET
DOOR LATCH
LEVELING FEET
SEISMIC FLOOR ANCHOR BRACKETS
CONFIGURABLE TOPS
TOP RAILS
UNIVERSAL FRONT DOORS
VENTED REAR DOORS
WRINKLE TOUCH-UP PAINT
RISER BASES

for details- see the universal cabinet options pages of the Master catalog

Architects' and Engineers' Specifications

- ERK shall be M.A.P. model number ERK-XXYY (X=rackspaces req'd. Y= rack depth req'd.) (See chart prior to determining X & Y.)
- The ERK rack shall be constructed of the following materials:
 1. Rack top and bottom shall be 16-gauge CR Steel
 2. Sides shall be 16-gauge steel welded to structural supports of 16-gauge steel, giving an 1/8" thick structure
 3. Front rack rail shall be 11-gauge steel, with tapped 10-32 holes in universal E.I.A. spacing
 4. Rear doors shall be of 18-gauge CR Steel
 5. The ERK series rack shall be phosphate pre-treated and finished in a durable black powder coat
 6. The ERK shall be of welded construction

OPTIONS

- Front doors shall be 16-gauge steel & available as part #FD-XX (solid), VFD-XX (vented), PFD-XX (plexi), (X=# of rack spaces of ERK rack)
- Vented rear doors shall be 16-gauge steel & available as part #ERK-VRD-XX, (X=# of rackspaces of ERK rack)
- Top panels, 16-gauge steel, in 4 styles - part # ERK-ST (blank), #ERK-10FT (10" fan), #ERK-4FT (three 4 1/2" fans), #ERK-VT (vented)
- Caster base, four casters shall have a total weight capacity of 1300 pounds, part # CBS-ERK-YY (Y= cabinet depth)
- Leveling feet part # LF, shall be 3/8" threaded steel, adjustable from top or bottom
- Keyless Latch, replaces keylock & fits front & rear doors, part # LATCH
- Lacer strip, heavily perforated, 78" long, 11-gauge steel, part # LACE
- Rear rail kit, 11-gauge, 10-32 threaded, sold in pairs, hardware included, part # ERK-RRXX (X=# of rackspaces)
- Seismic Zone-4 compliancy floor anchor kit, part# ERK-Z4
- AX-S option available (See AX-S Spec sheet 96-055S)

The RACK SYSTEM EXPERTS

www.middleatlantic.com

ERK basic dimensions

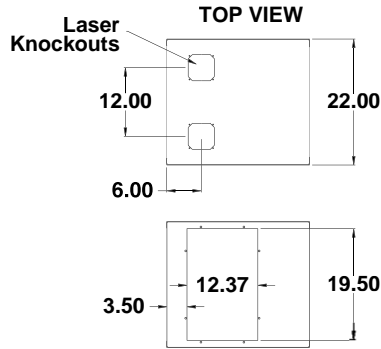
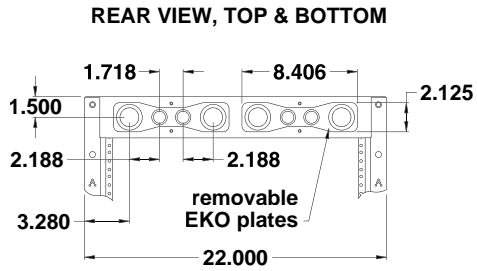

top for
ERK-18XX
ERK-21XX
ERK-27XX

top for
ERK-35XX
ERK-40XX
ERK-44XX

Part #	'A'	'B'	'C'	'D'	'E'
ERK-4425	81.125"	77.125"	75.125"	25.0"	20.25"
ERK-4025	74.125"	70.125"	68.125"	25.0"	20.25"
ERK-3525	65.375"	61.375"	59.375"	25.0"	20.25"
ERK-2725	51.375"	47.375"	45.375"	25.0"	20.25"
ERK-2125	40.875"	36.875"	34.875"	25.0"	20.25"
ERK-1825	35.625"	31.625"	29.625"	25.0"	20.25"
ERK-4420	81.125"	77.125"	75.125"	20.0"	15.25"
ERK-4020	74.125"	70.125"	68.125"	20.0"	15.25"
ERK-3520	65.375"	61.375"	59.375"	20.0"	15.25"
ERK-2720	51.375"	47.375"	45.375"	20.0"	15.25"
ERK-2120	40.875"	36.875"	34.875"	20.0"	15.25"
ERK-1820	35.625"	31.625"	29.625"	20.0"	15.25"

TOP VIEW OF ERK SIDE SECTIONAL VIEW

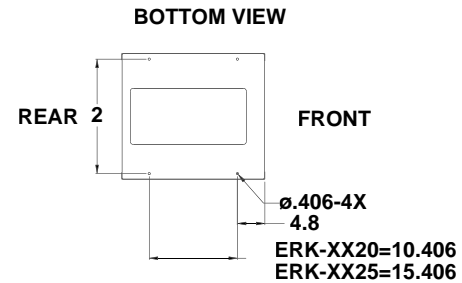
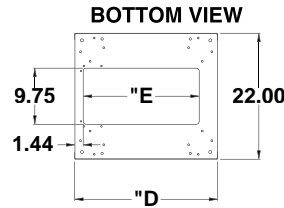
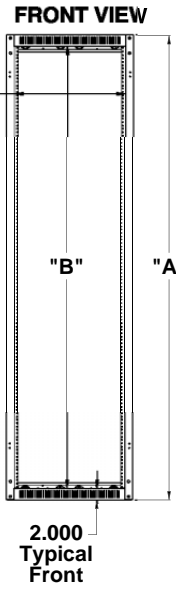
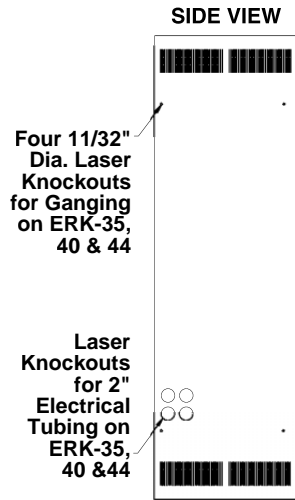
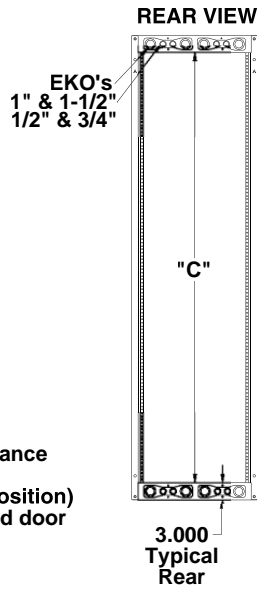
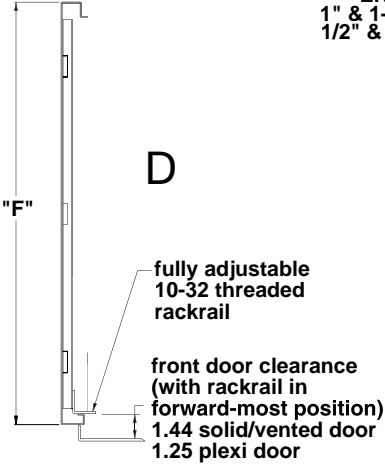

FLOOR MOUNTING LOCATIONS

ALL DIMENSIONS IN INCHES UNLESS OTHERWISE NOTED

ERK top options

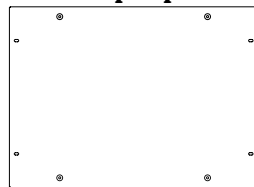

ERK-ST

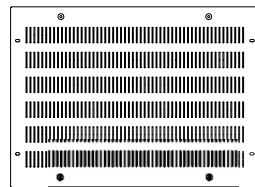

ERK-VT

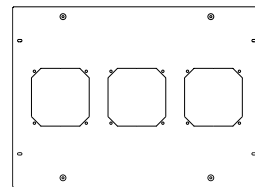

ERK-4FT

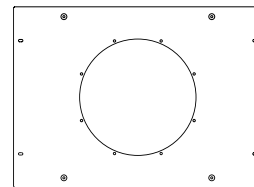

ERK-10FT